

SUBMITTAL DATA

BFLR18HPJ1FA / KULA18HPJ1OB
18000 BTU/H Floor/Ceiling Heat Pump System

Job Name

Purchaser

Submitted to

Unit Designation

Location

Date

Engineer

For

Schedule No.



BFLR18HPJ1FA



KULA18HPJ1OB



YAP1FFB



XE71

GENERAL FEATURES

- AHRI Certificate: -
- Quiet Operation and Multi-Speed Fan
- Floor Stand or Ceiling Mount
- Multi-Directional Air Flow
- Wireless Remote with LCD Display Included
- Wired Controller Included
- Low Ambient Cooling down to -20°F (Range -20°F to 122°F)
- Low Ambient Heating down to -22°F (Range -22°F to 86°F)
- Coil (Indoor and Outdoor) Copper Tube / Aluminum Fin
- Blue Colored Fin - 500 Hrs Salt Spray Tested

SPECIFICATIONS, FEATURES & FUNCTION SUMMARY

SPECIFICATIONS BFLR18HPJ1FA / KULA18HPJ1OB

System Type HEAT PUMP

SYSTEM PERFORMANCE

Cooling	Min - Max	Btu/h	5100 - 21154
	Capacity @95°F	Btu/h	17000
Heating	Min - Max	Btu/h	5800 - 21495
	Capacity @5°F	Btu/h	
	Capacity @17°F	Btu/h	
	Capacity @47°F	W	17800
SEER2			19.0
EER2			11.3
HSPF2			8.3
COP @5°F			
COP @47°F			3.3
Cooling Temperature Range	°F		-20 - 122
Heating Temperature Range	°F		-22 - 86
Refrigerant Type			R410A

INDOOR UNIT BFLR18HPJ1FA

Air flow (Min-Max)	CFM	241 - 400
Sound Pressure Level (Min - Max)	dB(A)	27 - 38
Dehumidification	pt/hr	3.8
External Dimensions (W x H x D)	in	34-1/4 x 26-1/4 x 9-1/4
Package Dimension (W x H x D)	in	40-1/2 x 30-1/4 x 11-1/4
Net Weight	lbs	56.3
Gross Weight	lbs	67.3

OUTDOOR UNIT KULA18HPJ1OB

Compressor Type	GREE G-10 / 2 - STAGE INVERTER	
Sound Pressure Level	dB(A)	59
External Dimensions (W x H x D)	in	37-3/4 x 26 x 15-7/8
Package Dimension (W x H x D)	in	40-5/8 x 29-1/16 x 18
Net Weight	lbs	98.1
Gross Weight	lbs	106.9

REFRIGERANT PIPING

Refrigerant Charge - R410A	oz	54.7
Additional Charge	oz/ft	0.5
Line Set Size by Indoor Unit (Liquid - Gas)	in	1/4 - 1/2
Outdoor Service Valve Size (Liquid - Gas)	in	1/4 - 5/8
Pre-Charge Length	ft	25
Pipe Length (Min - Max)	ft	10 - 82
Max. Pipe Elevation	ft	33

ELECTRICAL

Power Supply	208-230V / 1Ph / 60Hz (Powered by the Outdoor Unit)	
Voltage Range (Min - Max)	VAC	187 - 253
Rated Current - Cooling	A	11.5
Rated Current - Heating	A	11.5
MCA	A	14
MOCP	A	20
Suggested Breaker Size	A	15
Main Power Wire Size	AWG	Per Local Code
Interconnecting Wire Size	AWG	14 / 4

FEATURES & FUNCTIONS SUMMARY BFLR18HPJ1FA / KULA18HPJ1OB

SYSTEM FEATURES

Inverter Type	G10
Ultra Low Frequency Torque Control	Yes
Power Factor Correction	Yes
Compressor Type - Inverter	High Efficiency Rotary
Basepan With Electric Heater	Yes
Indoor & Outdoor Fin Coating (Blue Fin)	Yes
Intelligent Defrosting	Yes
Intelligent Preheating	Yes
Low Voltage Startup	Yes
Memory/Power Failure Recovery	Yes
Self Diagnosis	Yes
Wired Controller Interface	Yes
WiFi Included	No
Indoor Fan Type	Centrifugal
Multi Fan Speeds	4 Speeds
Indoor Unit Display	Yes
Auxiliary Electrical Heater	No
Ventilation (Outdoor Air)	No

REMOTE CONTROLLER FUNCTIONS

Auto Mode	Yes
Auto Fan	Yes
Auto Swing (Horizontal Auto Swing)	No
Auto Swing (Vertical Auto Swing)	Yes
Clock	Yes
Dry Mode	Yes
Dry Anti-Mildew (X-Fan) Mode	Yes
Energy Saving Mode	Yes
Dirty Filter Alert	No
Fan Speed Control (4 Speeds)	Yes
I Feel Function	Yes
Privacy Lock	Yes
Quiet Mode	Yes
Room Temperature Display	No
Sleep Mode (Normal Sleep)	Yes
4 Sleep Mode Options	No
Timer Mode	Yes
Turbo Mode	Yes
Display On/Off Control	Yes
Freeze Guard Mode	Yes
Power Failure Mode	Yes

DIMENSIONS

INDOOR UNIT

Unit: inch

BFLR18HPJIFA	
DIMENSIONS	
A	34-1/4
B	9-1/4
C	32
D	12-1/2
H	26-1/4

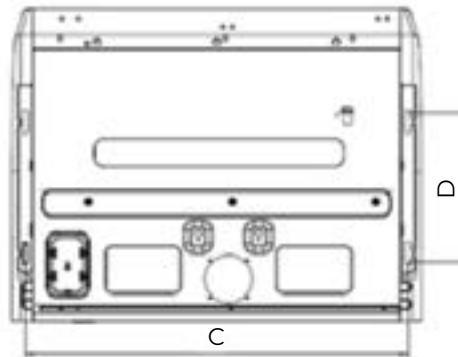
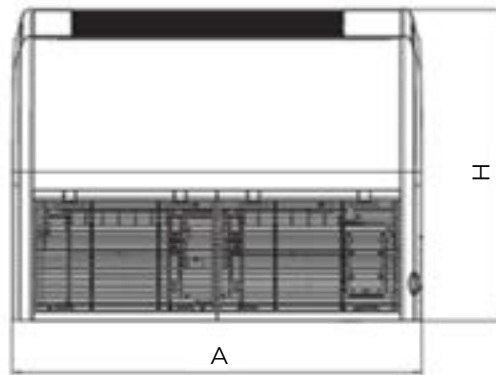

OUTDOOR UNIT

Unit: inch

KULA18HPJIOB	
DIMENSIONS	
A	35
B	37-23/32
C	25-63/64
D	13-25/64
E	15-53/64
F	22-7/16
G	14-39/64

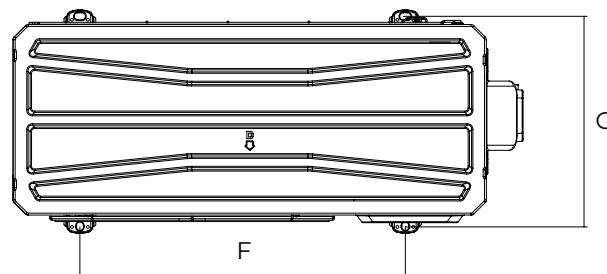
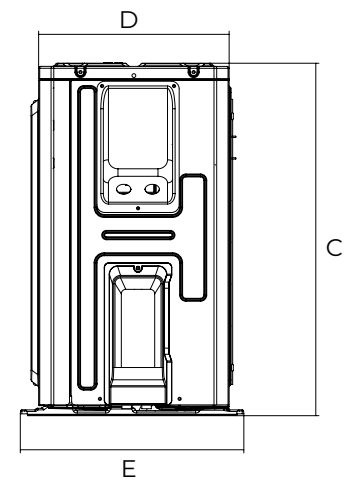
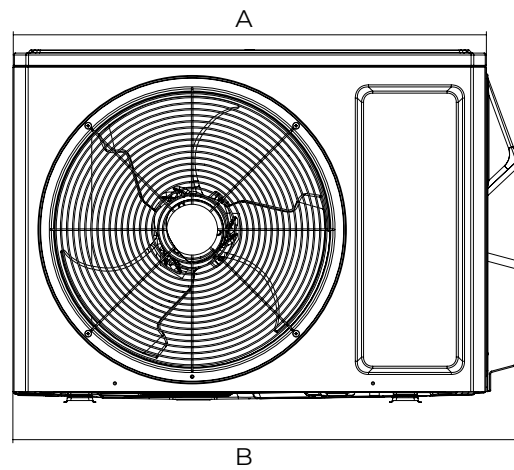

CLEARANCES

INDOOR UNIT Minimum clearance

DIMENSIONS	
A	60
B	12
C	39
D	6
E	90

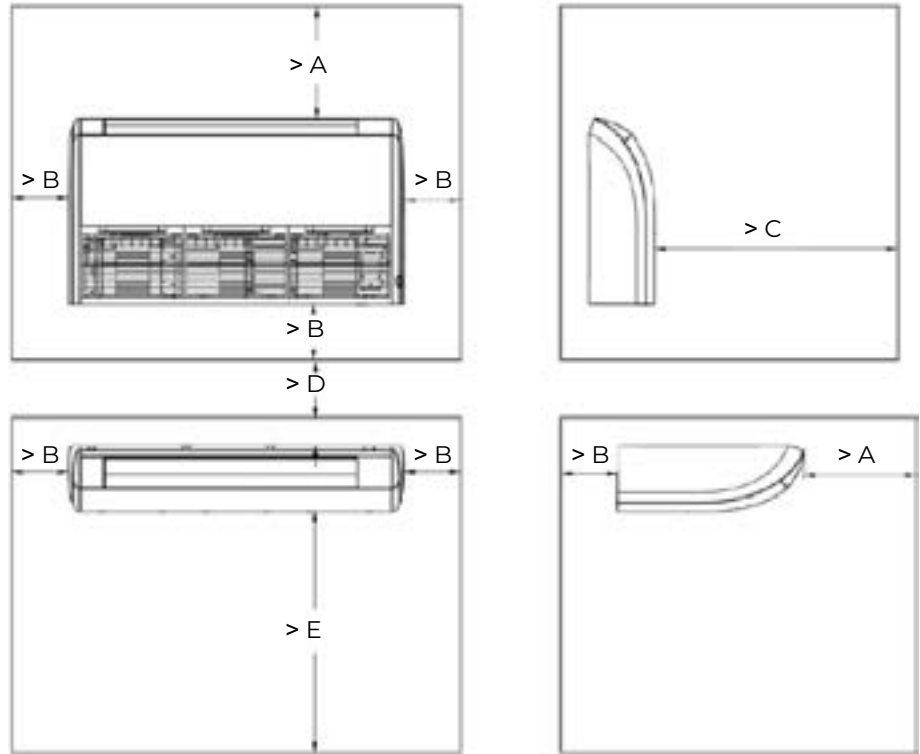

OUTDOOR UNIT Minimum clearance

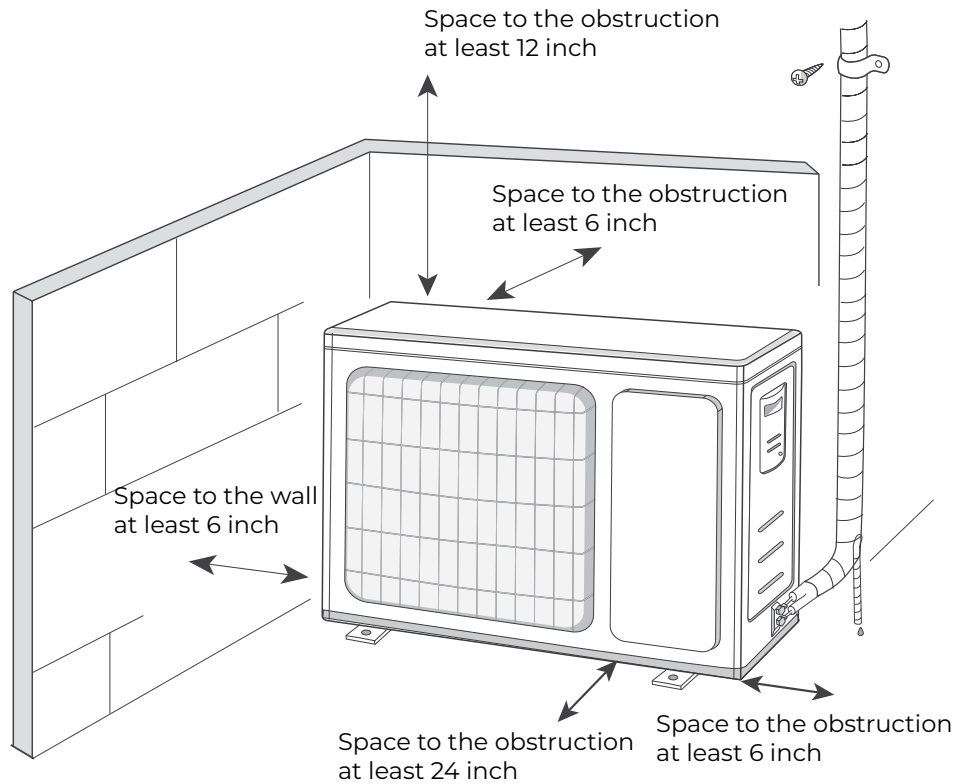
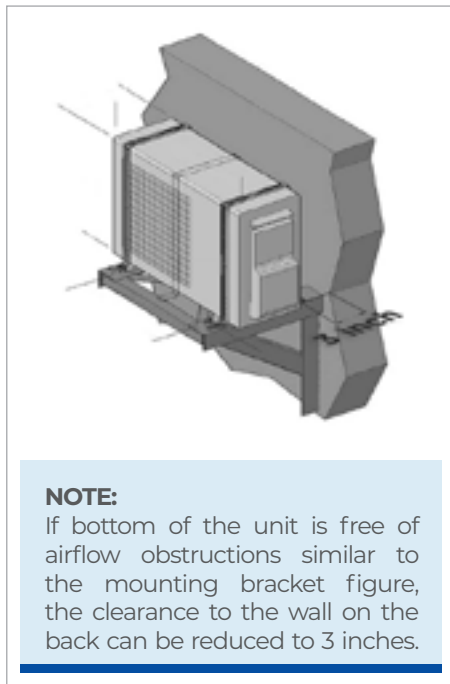

Specifications are subject to change without notice. Manufacturer reserves the right to discontinue or modify specifications or designs without notice or without incurring obligations. All Rights reserved.